

MINUETTE



MINUETTE
height 596 mm, lenght 540 mm. Gold finish (cod. 52).

STAINLESS STEEL
RADIATORS



Technical features:

- stainless brass towel warmer
- horizontal tubes 30 mm diameter
- side manifolds 30 mm diameter
- 1/2" Gas right threading
- maximum working pressure 10 bar
- maximum working temperature 95°C

Price included:

- valve and lockshield valve kit for connection to the heating system (iron connection 1/2") complete as in the photo and drawing illustrated below
- 2 wall fixings
- 1/2" air vent valve
- 1 blind plug
- 2 pipe covers

Finishes available

- Chrome-plated (cod. 50)
- Gold (cod. 52)
- Brushed Copper (cod. 5F)
- Satin Nickel (cod. 6E)
- Brushed Bronze (cod. 54)

Surcharge

Standard Connections

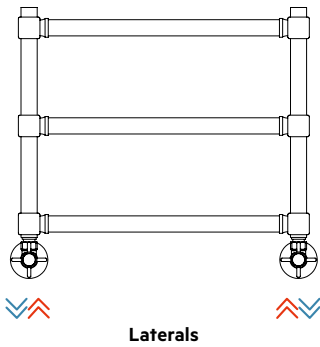

Connection dimensions with IRSAP valves

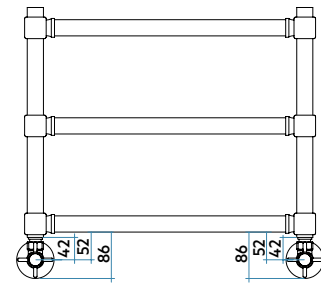

Hydraulic connection diagram

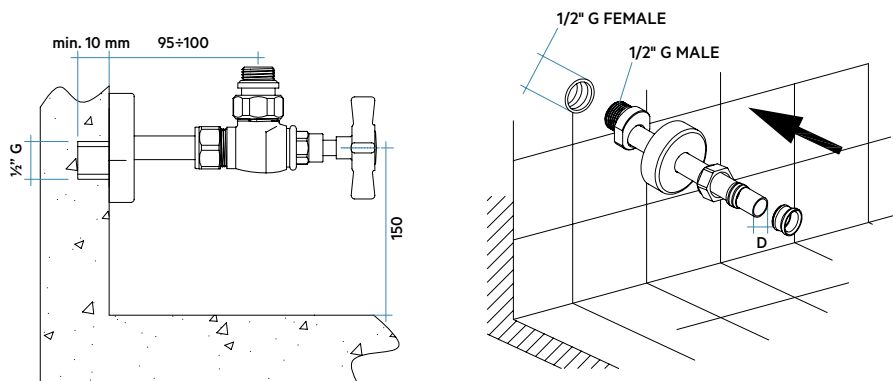

Finishes only for Minuette



Brushed Bronze **G**
Cod. 54
FINISHES



Brushed Copper **G**
Cod. 5F
FINISHES



Gold **G**
Cod. 52
FINISHES



Satin Nickel **G**
Cod. 6E
FINISHES



Chrome-plated **G**
Cod. 50
FINISHES

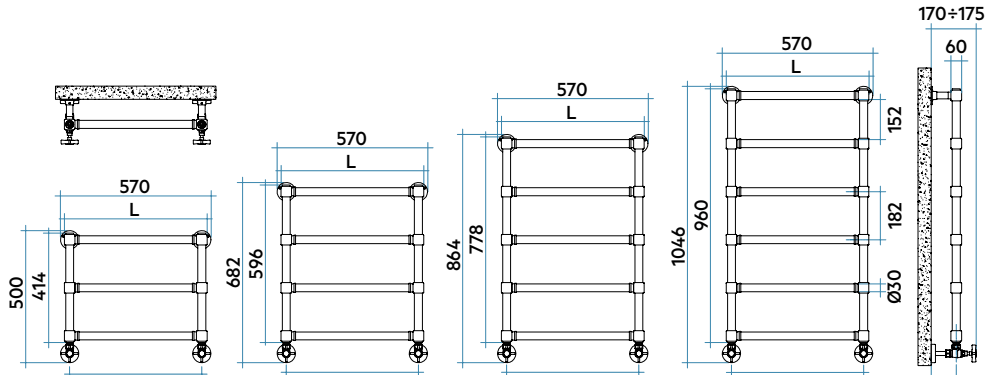

Chrome-plated

Model	Code	Depth P mm	Height H mm	Width L mm	Conn. C. L' mm	Weight Kg	Cap. lt	Thermal Power				Exp. n.	
								$\Delta t=50^{\circ}\text{C}$ Btu/h	$\Delta t=40^{\circ}\text{C}$ Watt	$\Delta t=30^{\circ}\text{C}$ Watt (*)	$\Delta t=20^{\circ}\text{C}$ Watt		
414 - 3 rails - 2 espaces	MGU054 B 50 IR 01 NNN	60	414	540	500	5,8	1,2	394	116	88	62	38	1,203
596 - 4 rails - 3 espaces	MGS054 B 50 IR 01 NNN	60	596	540	500	7,8	1,7	526	154	118	83	51	1,203
778 - 5 rails - 4 espaces	MGP054 B 50 IR 01 NNN	60	778	540	500	9,7	2,1	657	192	146	102	61	1,252
960 - 6 rails - 5 espaces	MGM054 B 50 IR 01 NNN	60	960	540	500	11,7	2,6	790	232	175	121	73	1,263

Brushed Bronze

Model	Code	Depth P mm	Height H mm	Width L mm	Conn. C. L' mm	Weight Kg	Cap. lt	Thermal Power				Exp. n.	
								$\Delta t=50^{\circ}\text{C}$ Btu/h	$\Delta t=40^{\circ}\text{C}$ Watt	$\Delta t=30^{\circ}\text{C}$ Watt (*)	$\Delta t=20^{\circ}\text{C}$ Watt		
414 - 3 rails - 2 espaces	MGU054 B 54 IR 01 NNN	60	414	540	500	5,8	1,2	453	133	102	72	44	1,203
596 - 4 rails - 3 espaces	MGS054 B 54 IR 01 NNN	60	596	540	500	7,8	1,7	605	177	135	96	59	1,203
778 - 5 rails - 4 espaces	MGP054 B 54 IR 01 NNN	60	778	540	500	9,7	2,1	756	221	167	117	70	1,252
960 - 6 rails - 5 espaces	MGM054 B 54 IR 01 NNN	60	960	540	500	11,7	2,6	909	266	201	140	84	1,263

Gold / Brushed Copper / Satin Nickel

Model	Code	Depth P mm	Height H mm	Width L mm	Conn. C. L' mm	Weight Kg	Cap. lt	Thermal Power				Exp. n.	
								$\Delta t=50^{\circ}\text{C}$ Btu/h	$\Delta t=40^{\circ}\text{C}$ Watt	$\Delta t=30^{\circ}\text{C}$ Watt (*)	$\Delta t=20^{\circ}\text{C}$ Watt		
414 - 3 rails - 2 espaces	MGU054 B XX IR 01 NNN	60	414	540	500	5,8	1,2	394	116	88	62	38	1,203
596 - 4 rails - 3 espaces	MGS054 B XX IR 01 NNN	60	596	540	500	7,8	1,7	526	154	118	83	51	1,203
778 - 5 rails - 4 espaces	MGP054 B XX IR 01 NNN	60	778	540	500	9,7	2,1	657	192	146	102	61	1,252
960 - 6 rails - 5 espaces	MGM054 B XX IR 01 NNN	60	960	540	500	11,7	2,6	790	232	175	121	73	1,263

XX = 52 for Gold finish code; **5F** for Brushed Copper finish code; **6E** for Satin Nickel finish code; **50** = Chrome-plated finish; **54** = Brushed Bronze finish.

(*) Thanks to the high performance of Irsap MINUETTE radiators, the ideal Δt for low temperature projects is Δt at 30°C.

For Δt different from 50°C use the formula: $Q=Q_n (\Delta t / 50)^n$

Key Codes

