



# Hudevad SC



Technical datasheet

# Key benefits

---



## **Traditional craftsmanship**

*Completely handmade unique design*



## **Fully soldered solution**

*No removable parts making it completely tamper-proof*



## **Tailor-made**

*Customise height, length, and element spacing to suit any project*



## **Open construction**

*Lets in the light making it ideal to install in front of glazing*

# Index

---

Description.....	4
Illustrations .....	5
Dimensions.....	5
Length and element spacing table .....	6
Tapping dimensions .....	7
Build-in dimensions .....	9
Wall mounted.....	9
Floor mounted.....	9
Output .....	15
SC single (SCE) .....	15
SC double (SCE) .....	16
Options.....	17
Accessories .....	18
Tappings .....	18

# Description

---

The Hudevad SC radiator is the perfect heating source for making a statement. The radiator has a high-end and timeless design that is highly customizable for the perfect fit in any environment. The radiator doesn't block the light, as its flat elements are designed for giving the room spaciousness and the impression of 'air'. The SC radiator is ideal for many applications due to its unique design that blends into the room architecture without stealing focus.

Material	Headers: Square steel tube 35 x 35 x 2.5 mm to EN 10305-5 Flat tube elements: Steel tube 70 x 11 x 1.9 mm to EN 10305-5
Test pressure	10 bar
Max. operating pressure	7.7 bar in accordance with EN 442
Max. operating temperature	95°C
Surface treatment	Pretreatment: Degreasing and passivation Priming: Primed with water based paint in pale grey Surface treatment in accordance with DIN 55900 and EN 442
Element spacing	40, 60 or 80 mm
Length	80-4600 mm Max. length, however, depends on height and weight
Height	300-3000 mm in increments of 40-60-80 mm, depending of element spacing
Depth	SCE: 98 mm. SCD: 160 mm
Tappings	15 tapping options 1/8", 3/8", 1/2" and 3/4"
Installation	Wall mounted, on feet or on mounting pillars Brackets are included. Air vents and plugs are included.
Optional extras	Fixed feet SF124 Free standing feet SH124 Waterway feet SK150 Waterway feet SE150 Mounting pillars SC477-482
Colour	Powder coated in white RAL 9010. Gloss 70 Option: Painted in other standard RAL and BS colours

# Illustration

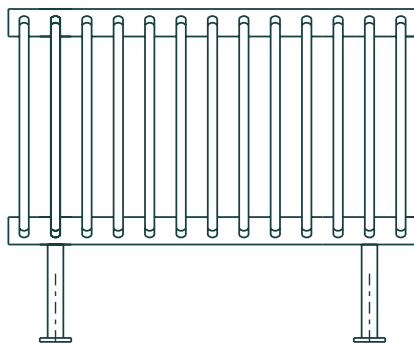

# Dimensions

Radiator length is calculated as:

Element spacing  $S \times (\text{no. of elements} - 1) + 40 \text{ mm}$

No. of elements for a given radiator length is calculated as:

$(\text{radiator length } L - 40) / \text{element spacing } S + 1$

Length table: see page 6

*Note: SC higher than 1400 mm is braced with a steel rail on the rear side of the flat tube elements*

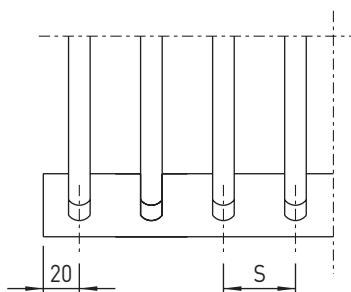

## Length and element spacing table

Length mm	Element spacing, mm			Length mm	Element spacing, mm			Length mm	Element spacing, mm			Length mm	Element spacing, mm		
	40	60	80		40	60	80		40	60	80		40	60	80
80	2			1280	32			2480	62			3680	92		
100		2		1300		22		2500		42		3700		62	
120	3		2	1320	33		17	2520	63		32	3720	93		47
160	4	3		1360	34	23		2560	64	43		3760	94	63	
200	5		3	1400	35		18	2600	65		33	3800	95		48
220		4		1420		24		2620		44		3820		64	
240	6			1440	36			2640	66			3840	96		
280	7	5	4	1480	37	25	19	2680	67	45	34	3880	97	65	49
320	8			1520	38			2720	68			3920	98		
340		6		1540		26		2740		46		3940		66	
360	9		5	1560	39		20	2760	69		35	3960	99		50
400	10	7		1600	40	27		2800	70	47		4000	100	67	
440	11		6	1640	41		21	2840	71		36	4040	101		51
460		8		1660		28		2860		48		4060		68	
480	12			1680	42			2880	72			4080	102		
520	13	9	7	1720	43	29	22	2920	73	49	37	4120	103	69	52
560	14			1760	44			2960	74			4160	104		
580		10		1780		30		2980		50		4180		70	
600	15		8	1800	45		23	3000	75		38	4200	105		53
640	16	11		1840	46	31		3040	76	51		4240	106	71	
680	17		9	1880	47		24	3080	77		39	4280	107		54
700		12		1900		32		3100		52		4300		72	
720	18			1920	48			3120	78			4320	108		
760	19	13	10	1960	49	33	25	3160	79	53	40	4360	109	73	55
800	20			2000	50			3200	80			4400	110		
820		14		2020		34		3220		54		4420		74	
840	21		11	2040	51		26	3240	81		41	4440	111		56
880	22	15		2080	52	35		3280	82	55		4480	112	75	
920	23		12	2120	53		27	3320	83		42	4520	113		57
940		16		2140		36		3340		56		4540		76	
960	24			2160	54			3360	84			4560	114		
1000	25	17	13	2200	55	37	28	3400	85	57	43	4600	115	77	58
1040	26			2240	56			3440	86						
1060		18		2260		38		3460		58					
1080	27		14	2280	57		29	3480	87		44				
1120	28	19		2320	58	39		3520	88	59					
1160	29		15	2360	59		30	3560	89		45				
1180		20		2380		40		3580		60					
1200	30			2400	60			3600	90						
1240	31	21	16	2440	61	41	31	3640	91	61	46				

## Tapping dimensions

### Side tappings ABCD

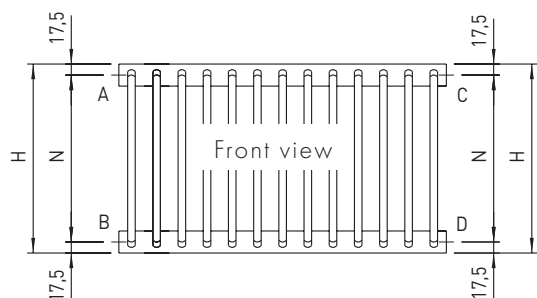

SCE, profile

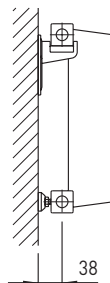

SCD, profile

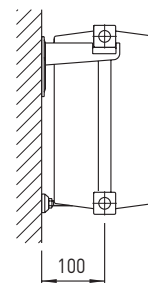

Centre distance N is calculated as: Radiator height (H)-35 mm

B-D tapping combination:

To ensure optimum water flow, bottom headers are factory fitted with a diverter plate. Therefore, flow and return must be stated when ordering.

### Top and underside tappings E, F, G, H and M

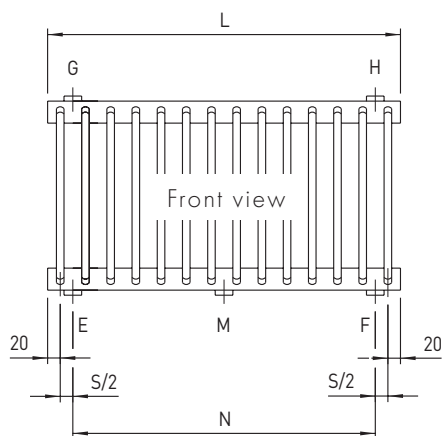

SCE, profile

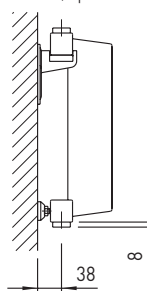

SCD, profile

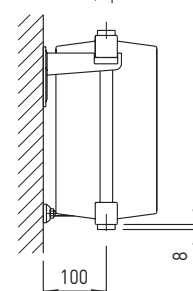

Centre distance N at tapping E-F or G-H is calculated as: Radiator length (L)-element spacing (S)-40 mm  
M tapping is placed in the centre of length L.

NOTE: Depending on tapping combination, bottom or top headers are factory fitted with a diverter plate to ensure optimum water flow.

Flow and return must be stated when ordering.

### Underside tapings EE/FF

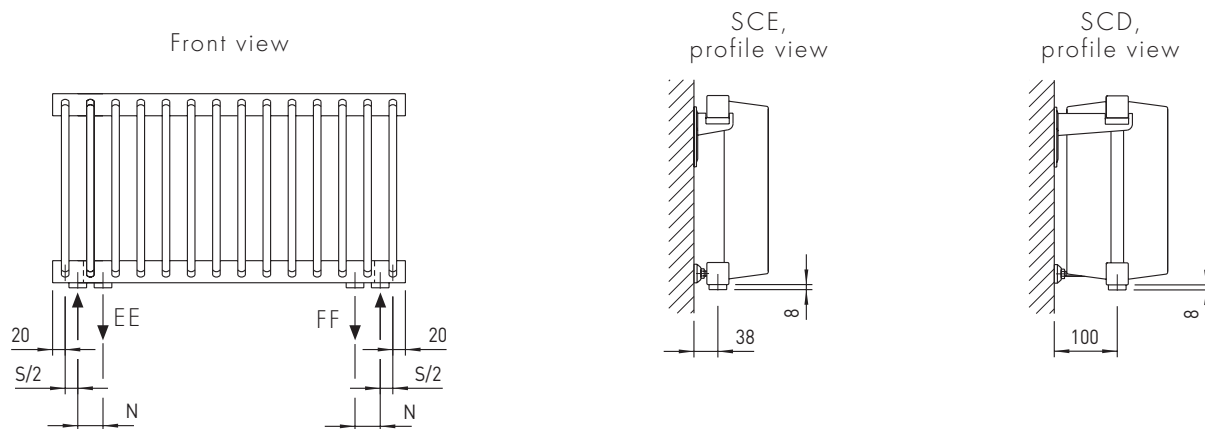

Centre distance N at tapping EE/FF corresponds to element spacing S

Note: Flow is always placed in the outer tapping. Radiator is factory fitted with a diverter plate between tapings to ensure optimum water flow.

### Rear tapings Ex, Fx, Gx and HX

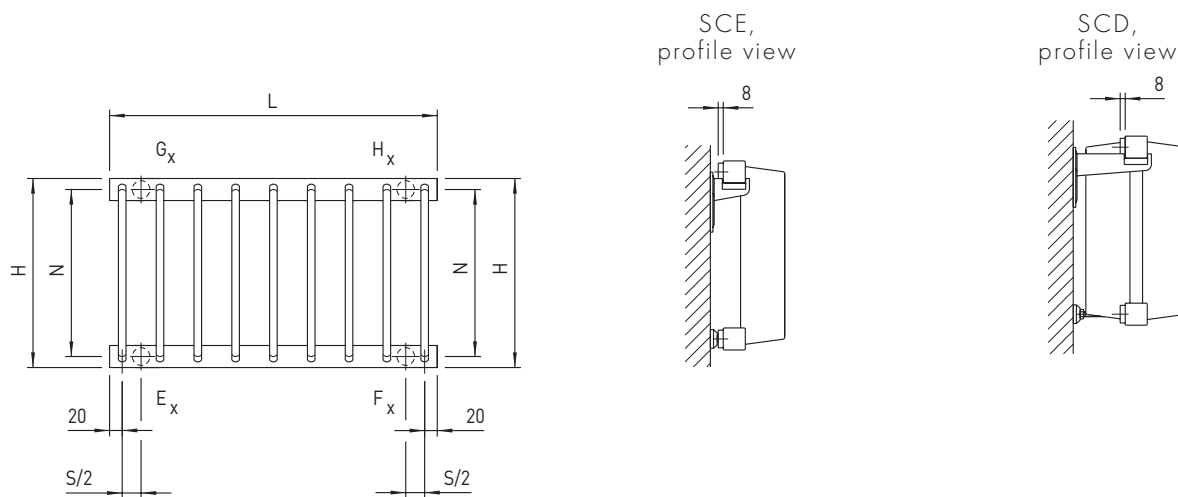

Centre distance N is calculated as: Radiator height (H)-35 mm

Note: Depending on tapping combination, bottom or top headers are factory fitted with a diverter plate to ensure optimum water flow.

Flow and return must be stated when ordering.

Note: SCD with element spacing 40 mm cannot be supplied with rear tapings.



# Build-in dimensions

## SC wall mounted

SC single (SCE), profile view

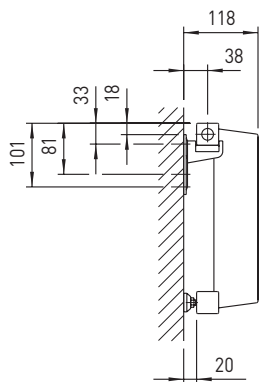

SC double (SCD), profile view

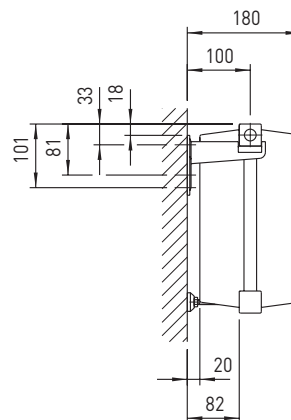

No. of brackets and spacers	Element spacing					
	40 mm		60 mm		80 mm	
	Elements	L, mm	Elements	L, mm	Elements	L, mm
2/2	2-25	80-1000	2-17	100-1000	2-13	120-1000
3/2	26-50	1040-2000	18-33	1060-1960	14-25	1080-1960
4/3	51-75	2040-3000	34-50	2020-2980	26-38	2040-3000
5/4	76-115	3040-4600	51-77	3040-4600	39-58	3080-4600

## SC floor mounted

### Fixed feet SF124

Feet SF124, profile view

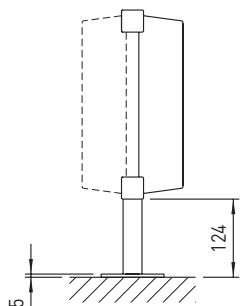

Foot plate for feet SF124, top view

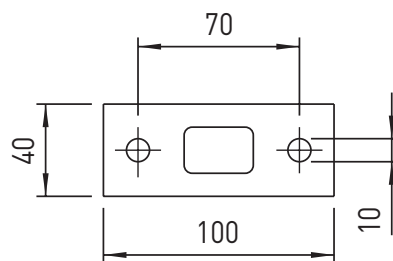

Application For use where wall mounting is not possible, e.g. in front of glazing

Construction 20 x 30 x 2 mm steel tube with foot plate of 5 mm steel  
Feet are welded onto the radiator

Height 124 mm from upper floor surface to lower edge of radiator

Colour Same as radiator

Note: Limitations in radiator height, see table below

**Front view**

Radiator with 2 feet SF124

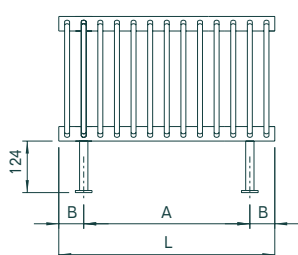

Radiator with 3 feet SF124

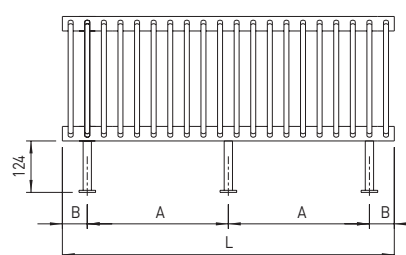

Radiator with 4 feet SF124

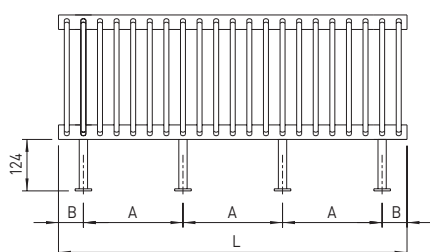

SCE with fixed feet SF124

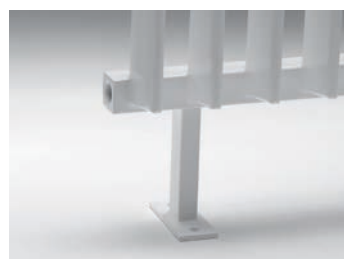

**Limitations in radiator height**

Radiator height, mm	Comments
300-600	-
700-3000	Top restraint by wall brackets is required (supplied)

**Distance B at different tapping combinations**

Element spacing, mm	Tapping combinations		
	ABCD	EF/FE	EE/FF
40	60	100	140
60	80	140	200
80	100	180	260

**Position and no. of feet**

No. of feet	Element spacing						
	40 mm			60 mm		80 mm	
	A, mm	Elements	L, mm	Elements	L, mm	Elements	L, mm
2	L - 2B	2-40	80-1600	2-27	100-1600	2-20	20-1560
3	(L - 2B)/2	41-70	1640-2800	28-47	1660-2800	21-35	1640-2760
4	(L - 2B)/3	71-115	2840-4600	48-77	2860-4600	36-58	2840-4600

Feet will be welded under an element or between 2 elements. Therefore, distance A may vary. Distance B depends on tapping combination, see table above.

### Free standing feet SH124

Note: Max. radiator height 800 mm

Feet SH124, profile view

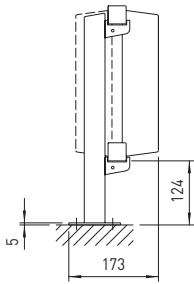

Foot plate for feet SH124, top view

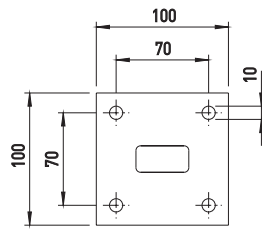

SCE with free standing feet SH124

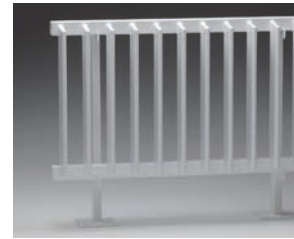

### Waterway feet SK150

Note: Max. radiator height 800 mm  
Total length: Radiator length + 90 mm

Feet SK150, profile view

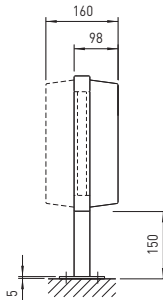

Foot plate for feet SK150, top view

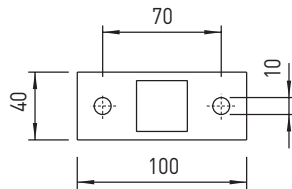

SCE with waterway feet SK150



### Waterway feet SE150

Note: Max. radiator height 800 mm

SCE, feet SE150, profile

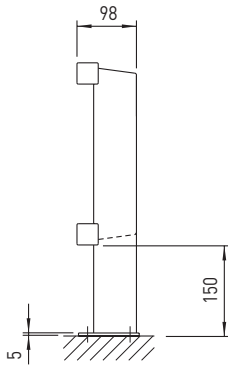

SCD, feet SE150, profile

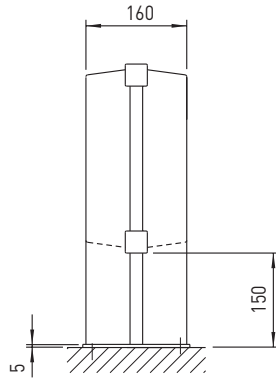

SCE with waterway feet SE150



SCE, foot plate for feet SE150, top view

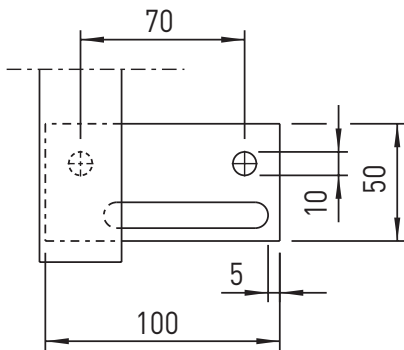

SCD, foot plate for feet SE150, top view

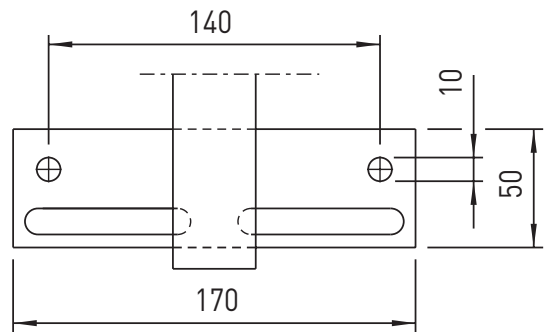

### Mounting pillars SC477-SC482

Note: Max. radiator height 800 mm

Casing for mounting pillar

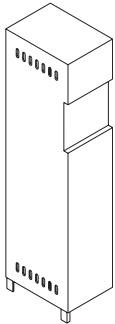

Upright for mounting pillar

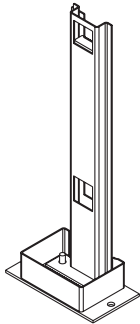

SCD with mounting pillars

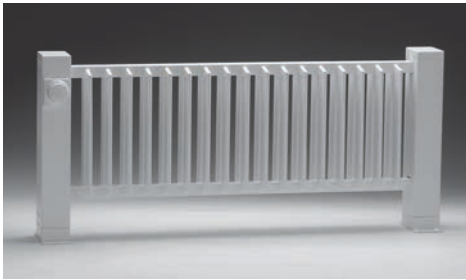

Principle of application for SC477

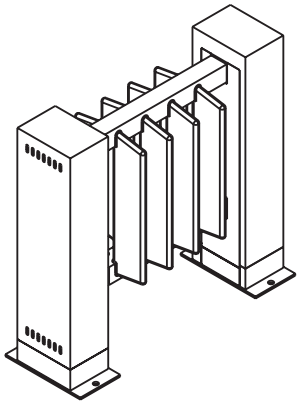

SC477. End pillar. Same unit is used as right or left end pillar

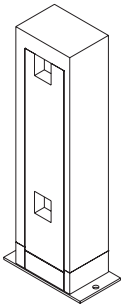
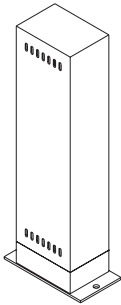

Principle of application for SC477, 480 and 479

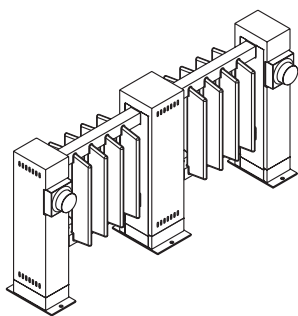

SC478. Left end pillar for built-in valve

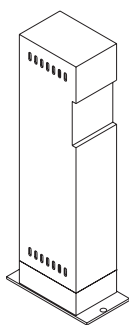

SC480. Central pillar for 2 radiators

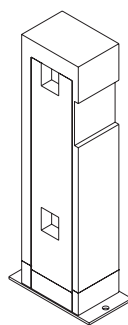

SC479. Right end pillar for built-in valve

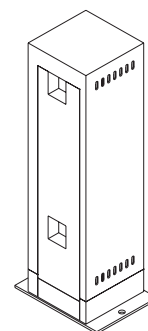

Principle of application for SC481 and 482

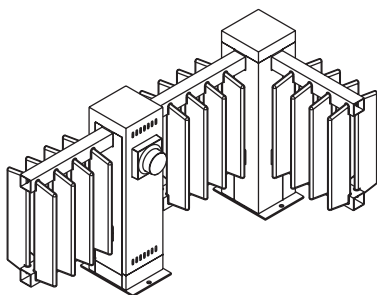

SC481. Central pillar for 2 radiators and built-in valve

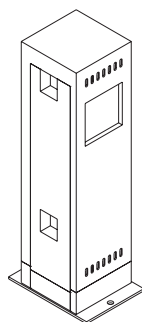

SC482. 90° corner pillar

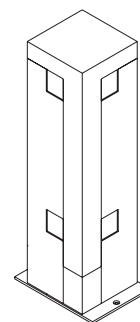

# Output

## SC single (SCE)

Height mm	W/m, 75°/65°/20°			W/m, 55°/45°/20°			W/m, 90°/70°/20°			Water content litres/ element	Weight kg/ element	Max. length, mm		
	Element spacing, mm			Element spacing, mm			Element spacing, mm					Element spacing, mm		
	40	60	80	40	60	80	40	60	80	40	60	80		
<b>300</b>	595	469	413	304	240	211	749	592	519	0.25	0.9	4600	4600	4600
<b>400</b>	753	590	514	385	301	263	948	745	646	0.30	1.1	4600	4600	4600
<b>500</b>	908	707	611	464	361	312	1143	894	769	0.35	1.4	4600	4600	4600
<b>600</b>	1058	821	705	540	419	360	1333	1039	887	0.40	1.6	4600	4600	4600
<b>700</b>	1208	933	797	617	477	407	1523	1181	1004	0.45	1.8	4600	4600	4600
<b>800</b>	1355	1046	888	692	534	454	1710	1324	1119	0.50	2.1	4600	4600	4600
<b>900</b>	1505	1158	979	769	591	500	1901	1467	1235	0.55	2.3	4560	4600	4600
<b>1000</b>	1653	1270	1070	844	649	547	2088	1610	1351	0.60	2.5	4120	4600	4600
<b>1100</b>	1800	1382	1161	919	706	593	2276	1754	1466	0.65	2.7	3760	4600	4600
<b>1200</b>	1950	1494	1252	996	763	639	2467	1897	1582	0.70	3.0	3440	4600	4600
<b>1300</b>	2100	1608	1339	1073	821	684	2658	2043	1694	0.75	3.2	3200	4600	4600
<b>1400</b>	2253	1717	1430	1151	877	730	2852	2183	1810	0.80	3.4	2960	4300	4600
<b>1500</b>	2405	1836	1534	1228	938	784	3047	2336	1943	0.85	3.7	2760	4060	4600
<b>1600</b>	2550	1955	1625	1302	999	830	3233	2489	2060	0.90	3.9	2600	3820	4600
<b>1700</b>	2725	2074	1716	1392	1059	876	3457	2642	2176	0.95	4.1	1600	1600	1560
<b>1800</b>	2875	2193	1820	1468	1120	930	3649	2795	2310	1.00	4.4	1600	1600	1560
<b>1900</b>	3025	2312	1911	1545	1181	976	3841	2949	2427	1.05	4.6	1600	1600	1560
<b>2000</b>	3200	2448	2015	1634	1250	1029	4066	3124	2561	1.10	4.8	1600	1600	1560
<b>2100</b>	3350	2567	2119	1711	1311	1082	4259	3278	2695	1.15	5.0	1600	1600	1560
<b>2200</b>	3525	2686	2210	1800	1372	1129	4484	3432	2812	1.20	5.3	1600	1600	1560
<b>2300</b>	3700	2822	2314	1890	1441	1182	4709	3608	2946	1.25	5.5	1600	1600	1560
<b>2400</b>	3875	2958	2418	1979	1511	1235	4934	3785	3081	1.30	5.8	1600	1600	1560
<b>2500</b>	4025	3094	2535	2056	1580	1295	5128	3961	3232	1.35	6.0	1600	1600	1560
<b>2600</b>	4200	3230	2639	2145	1650	1348	5354	4138	3367	1.40	6.2	1600	1600	1560
<b>2700</b>	4400	3366	2743	2247	1719	1401	5612	4315	3502	1.45	6.4	1560	1600	1560
<b>2800</b>	4575	3502	2860	2337	1789	1461	5839	4492	3654	1.50	6.7	1480	1600	1560
<b>2900</b>	4750	3638	2977	2426	1858	1521	6065	4670	3806	1.55	6.9	1440	1600	1560
<b>3000</b>	4950	3791	3094	2528	1936	1580	6324	4869	3958	1.60	7.1	1400	1600	1560

## SC double (SCD)

Height mm	W/m, 75°/65°/20°			W/m, 55°/45°/20°			W/m, 90°/70°/20°			Water content litres/ element	Weight kg/ element	Max. length, mm		
	Element spacing, mm			Element spacing, mm			Element spacing, mm					Element spacing, mm		
	40	60	80	40	60	80	40	60	80			40	60	80
<b>300</b>	960	729	607	490	372	310	1217	927	768	0.37	1.5	4600	4600	4600
<b>400</b>	1225	942	780	626	481	398	1553	1199	987	0.46	2.0	4600	4600	4600
<b>500</b>	1483	1151	949	757	588	485	1881	1465	1202	0.55	2.4	4200	4600	4600
<b>600</b>	1738	1355	1114	888	692	569	2206	1725	1411	0.64	2.9	3520	4600	4600
<b>700</b>	1990	1557	1278	1016	795	653	2526	1982	1619	0.73	3.4	3040	4420	4600
<b>800</b>	2240	1751	1443	1144	894	737	2845	2229	1829	0.82	3.8	2640	3880	4600
<b>900</b>	2488	1955	1599	1271	999	817	3162	2490	2027	0.91	4.3	2360	3460	4520
<b>1000</b>	2725	2159	1768	1392	1103	903	3464	2750	2242	1.00	4.7	2120	3100	4040
<b>1100</b>	2975	2346	1924	1520	1198	983	3784	2988	2440	1.09	5.2	1920	2860	3720
<b>1200</b>	3225	2550	2080	1647	1302	1062	4103	3249	2639	1.18	5.7	1760	2620	3480
<b>1300</b>	3500	2737	2249	1788	1398	1149	4456	3487	2854	1.27	6.1	1640	2440	3240
<b>1400</b>	3750	2941	2405	1915	1502	1228	4776	3748	3053	1.36	6.6	1520	2260	3000
<b>1500</b>	4000	3128	2561	2043	1598	1308	5056	3987	3251	1.45	7.0	1400	2080	2760
<b>1600</b>	4250	3332	2730	2171	1702	1394	5417	4248	3467	1.54	7.5	1320	1960	2600
<b>1700</b>	4500	3519	2886	2298	1797	1474	5738	4487	3666	1.63	8.0	1240	1600	1560
<b>1800</b>	4775	3723	3055	2439	1902	1560	6092	4748	3882	1.72	8.4	1160	1600	1560
<b>1900</b>	5250	3910	3211	2682	1997	1640	6700	4988	4081	1.81	8.9	1120	1600	1560
<b>2000</b>	5300	4114	3380	2707	2101	1726	6768	5249	4297	1.90	9.3	1040	1540	1560
<b>2100</b>	5575	4301	3536	2848	2197	1806	7122	5488	4496	1.99	9.8	1000	1480	1560
<b>2200</b>	5825	4505	3705	2975	2301	1892	7444	5750	4713	2.08	10.3	960	1420	1560
<b>2300</b>	6100	4692	3874	3116	2397	1979	7799	5989	4929	2.17	10.7	920	1360	1560
<b>2400</b>	6375	4896	4030	3256	2501	2058	8154	6251	5128	2.26	11.2	880	1300	1560
<b>2500</b>	6675	5083	4199	3409	2596	2145	8542	6491	5345	2.35	11.6	840	1240	1560
<b>2600</b>	6950	5287	4368	3550	2700	2231	8898	6751	5562	2.44	12.1	800	1180	1560
<b>2700</b>	7225	5491	4537	3690	2805	2317	9255	7013	5779	2.53	12.6	800	1120	1480
<b>2800</b>	7525	5678	4706	3844	2900	2404	9643	7253	5995	2.62	13.0	760	1120	1480
<b>2900</b>	7825	5882	4888	3997	3004	2497	10031	7515	6229	2.71	13.5	720	1060	1400
<b>3000</b>	8100	6086	5057	4137	3109	2583	10389	7777	6446	2.80	13.9	720	1000	1320



# Options

Description	All SCE and SCD radiators can be supplied angled or curved. Tapping designations etc. follow the same principles as for straight radiators.
Output calculation, angled:	The exact no. of elements is determined by Hudevad taking ordered angle and element spacing into consideration.
Output calculation, curved:	When calculating the radiator output the length of the horizontal header and not the length of the wall is to be used.
Installation	Wall or floor mounted. Note: Unless otherwise specified, the radiator is supplied with bracket SB20 (SCE) or SB82 (SCD).  If alternative wall distance is required, please consult Hudevad.

## Internal angles

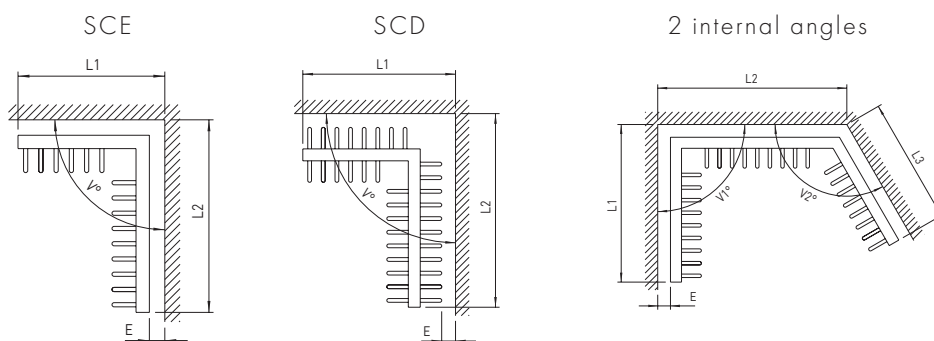

## External angle

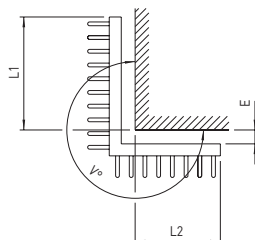

## Internal curve

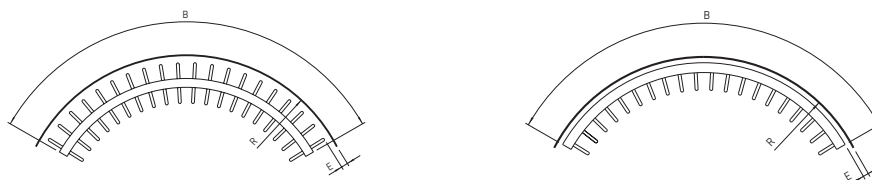

## External curve

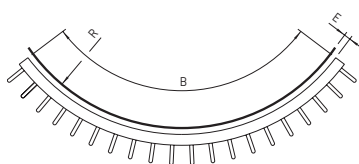

# Accessories

Bracket SB20

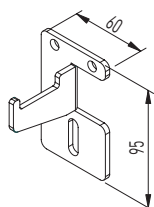

Bracket, profile view

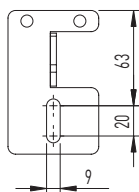

Spacer

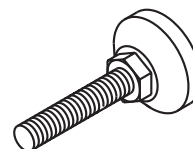

SCE uses bracket SB20 and SCD uses bracket SB82

Note: Bracket SB82 has same backplate with longer outreach

# Tappings

## Tapping designation

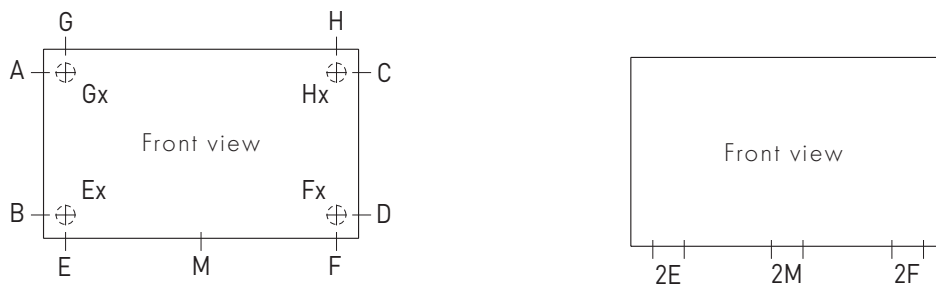

Standard tappings: 1/2" ABCD  
Options: 1/8", 3/8", and 3/4"

AB/CD centre distance = radiator height - 35 mm

Note: For lengths > 1800 mm please always state flow and return when ordering

## Tapping variations

